

THE JOURNAL  
OF THE  
AMERICAN CHEMICAL SOCIETY.

---

A NEW STABILITY TEST FOR NITROCELLULOSE  
POWDERS.

BY ALBERT P. SY.

Received March 30, 1903.

STABILITY tests, sometimes also called "heat tests," are applied to explosives to determine their stability or keeping qualities. During the process of manufacture these tests are made to determine if the product has been sufficiently purified, *i. e.*, freed from substances which might cause it to decompose spontaneously.

Before describing the new test, the more important and most used of the old tests, including the four used by the Ordnance Department, U. S. Army, are briefly mentioned; this is done so as to point out the weak points of these tests to those not familiar with them.

THE POTASSIUM-IODIDE-STARCH, OR ABEL TEST.

This test is prescribed and made by the Ordnance Department, U. S. A., as follows: 1.3 grains of the sample (air-dried) is placed in a test-tube in which there is suspended a test paper of potassium-iodide-starch, moistened to one-half its length with a 50 per cent. glycerin solution. This tube is then immersed in a bath kept at  $65.5^{\circ} \text{C.} \pm 1^{\circ}$ , for nitrocellulose, and at  $100^{\circ} \text{C.} \pm 1^{\circ}$ , for nitrocellulose powders. The test is ended at the appearance of a brown

or blue line on the test paper. For a good nitrocellulose this discoloration must not take place in less than forty minutes (at  $65.5^{\circ}$ ), and for a good nitrocellulose powder in not less than ten minutes (at  $100^{\circ}$ ). Powders containing nitroglycerin should stand this test for twenty minutes at  $65.5^{\circ}$ .

The discoloration of the test paper is due to the action of free iodine on the starch, the iodine being liberated from the potassium iodide by impurities or products of decomposition, principally oxides and acids of nitrogen volatilized from the explosive. This test is of some value to the manufacturer to determine whether his product has been thoroughly purified, and the test could be called "purity test" more appropriately than a stability test. When applied to finished products, this test has many weak points, as follows:

(1) It shows, in cases of decomposition of the sample during the test, only the beginning and not the continuation of the decomposition; it is more important to know how decomposition proceeds than when it begins.

(2) Traces of unstable nitro-compounds would show a nitrocellulose or powder in which they are found by this test to be bad; yet these traces of unstable compounds might not cause a decomposition of the explosive, if stored under ordinary conditions, and, considering that there is no indication of the effect of these unstable compounds, this test does not indicate the keeping qualities of the explosive.

(3) Traces of solvents left in a powder affect this test.

(4) The weakest point of this test is the fact that it can be masked by a number of substances which are sometimes added to the explosive for this purpose. These substances are mercuric chloride, mercury salts, carbonates, alkalies, amines, acetic ether, acetone, oils, vaseline, aniline, etc. Explosives containing masking substances are not accepted by the Ordnance Department.

(5) The test is affected by the condition of the sample, size of grains, whether freshly prepared for testing or exposed to air, and by moisture content. Charges of static electricity, which a powder acquires on rasping or cutting, affect the results of this test. Experiments along this line are being made by Capt. H. C. Aspinwall.

(6) Slight differences in test papers greatly affect the results of this test. (The test papers used by the Ordnance Department

are made in large quantities by Eimer and Amend, of New York, according to specification, thereby insuring greater uniformity than if made at different laboratories in small quantities. Manufacturers who have contracts with the government are supplied with these papers.)

(7) The personal equation of the operator enters as a factor in causing variations. It is no easy matter to decide just when there is the first appearance of a brown line on the test paper.

On account of the points mentioned, duplicates of the same powder have been known to vary from twenty to thirty minutes. The potassium-iodide-starch test has long been known to be unreliable, and the Ordnance Department condemns no explosives on results of this test alone.

#### THE ZINC-IODIDE-STARCH TEST.

This is a modification of the test just described, zinc iodide being used instead of potassium iodide (temperature  $80^{\circ}$  C.). Zinc iodide is more sensitive than potassium iodide, and also acts as a preservative of the test-paper. However, a greater sensitiveness is in no way an improvement of the potassium-iodide-starch test, and results obtained at this laboratory show that this test is not more reliable than the original, having all the weak points of the latter.

#### THE GUTTMANN TEST.

Instead of using a potassium-iodide-starch paper, Guttman recommended<sup>1</sup> a test paper moistened with a solution of diphenylamine in sulphuric acid. He claimed for his test the following advantages: (1) Not as sensitive as the potassium-iodide-starch test; (2) test papers more easily prepared; (3) masking substances do not interfere. The temperature used is  $70^{\circ}$  C., and nitrous fumes turn the colorless paper to a greenish-yellow and finally blue.

Thomas says<sup>2</sup> the diphenylamine test is unsatisfactory; it may be masked by the addition of diphenylamine to the explosive to be tested. Guttman himself admits that the blue color sometimes fails to appear. Moisture in the sample affects the test. Thomas as well as others failed to get a sharp end-reaction. The Guttman test was tried at this laboratory but gave unsatisfactory results, and was discontinued. Aspinwall,<sup>3</sup> Spica,<sup>4</sup> and Thomas

<sup>1</sup> *Ztschr. angew. Chem.* (1897), p. 233; *J. Soc. Chem. Ind.* (1897), p. 283.

<sup>2</sup> *Ibid.*, (1898), p. 1027.

<sup>3</sup> *J. Soc. Chem. Ind.*, May 31, 1902.

<sup>4</sup> *Rivista*, August, 1899.

found sufficient objections, after trial, to discard it. Major Nathan says<sup>1</sup> the test fails when testing volatile explosives, such as nitroglycerin, the latter being decomposed by the sulphuric acid on the test paper.

#### THE HESS TEST.<sup>2</sup>

Nitrocellulose is heated to 70° C. in a tube and, by means of a current of air, the volatile products of decomposition are carried into a dilute potassium-iodide-starch solution. Five observations are made: four colorimetric readings on the potassium-iodide-starch solution, and the time required for explosion of the sample. This test shows the beginning, and roughly, and for a short time also, how decomposition proceeds. The potassium-iodide-starch solution, however, is far too sensitive, and may show decomposition which in reality does not indicate instability of the explosive. Masking substances interfere as mentioned under the potassium-iodide-starch test, and results are affected by solvents in the sample, condition of the sample, difference in the testing solution, and personal equation of the operator.

#### THE HOITSEMA TEST.<sup>3</sup>

The explosive is heated for fifteen minutes at a constant temperature, and then, by means of a current of carbon dioxide, the volatile products of decomposition are passed through glass wool moistened with Guttman's diphenylamine solution. This operation is repeated, lowering the temperature 10° each time until a temperature is found at which no products of decomposition are found which give a color reaction with the test solution, this being considered the point at which decomposition ceases.

The test is too sensitive and subject to most of the objections mentioned under previous tests, especially under the Guttman test.

#### THE EXPLOSION TEST.

A small sample of the explosive (usually 0.1 gram) is placed in a strong test-tube which is then tightly corked and placed in a paraffin bath at 100° C. The bath is now stirred and heated so that the temperature increases 5° per minute. The temperature is noted at which the sample explodes.

<sup>1</sup> *J. Soc. Chem. Ind.* (1901), p. 10.

<sup>2</sup> *Mitth. u. Gegenst. d. Artill. u. Geniewerksens* (1879), p. 345; *Dingler's poly. J.*, **234**, 43.

<sup>3</sup> *Ztschr. angew. Chem.* (1889), p. 705.

A good nitrocellulose should not explode under 186° C.

A good nitrocellulose powder should not explode under 177° C.

A good nitroglycerin powder should not explode under 170° C.

These explosion points are required by the Ordnance Department; those required by other governments differ considerably. Judging from a great number of explosion tests made at this laboratory it seems that this test is reliable when the explosive is either very good or very bad. Variations in results may be caused by difference in manipulation of the test, especially in raising the temperature; the following table shows the effect on the explosion point of raising the temperature 1°, 2.5°, and 5° per minute, on powders Nos. 175, 178, 179 and 180.

Powder.	1°.	2.5°.	5°.
175	164	174.5	177
178	170	176	178
179	173	176	177
180	167	174.5	179

This table also shows that greater differences between the explosion points are obtained when the temperature is raised only 1° instead of 5° per minute.

#### THE THOMAS TEST.<sup>1</sup>

In this test the sample is heated in a glass-stoppered tube in an oil-bath for eight hours daily. A good nitroglycerin powder should stand four days' heating at 94°-96° C. without developing brown fumes (N<sub>2</sub>O<sub>4</sub>); a good nitrocellulose and nitrocellulose powder should not show fumes before three days, using a temperature of 99°-101° C.

These temperatures are too low to produce a decisive decomposition which may be observed by the appearance of brown fumes; it is hard to say just when brown fumes appear. Varying amounts of moisture and solvents in the powder will give different pressures in the closed tube, and consequently different results, since pressure affects decomposition.

#### THE 135° C. TEST.

Two and one-half grams of the explosive, and a piece of blue litmus paper are placed in a strong test-tube (320x18 mm.); the latter is tightly corked and placed in a bath at 135° C. Three observations are made: (1) Reddening of the litmus paper, (2)

<sup>1</sup> *Ztschr. angew. Chem.*, p. 1027 (1898).

brown fumes ( $N_2O_4$ ), and (3) explosion of the sample. The minimum time as required by government specifications for these three observations is as follows:

	Litmus red.	$N_2O_4$ .	Explosion.
Nitrocellulose.....	30 min.	45 min.	5 hrs.
Nitrocellulose powder.....	1 hr., 15 min.	2 hrs.	5 hrs.
Nitroglycerin powder.....	30 min.	45 min.	5 hrs.

After subjecting a large number of samples to this test it has been found that any one of these three observations alone is not always a correct indication of the condition or stability of the sample.

To illustrate:

	Litmus red.	$N_2O_4$ .	Explosion.
Powder No. 445.....	1.30	3.30	None in 5 hrs.
Powder No. 265.....	2.05	2.45	3.25

Powder No. 445 is a good, stable powder, while No. 265 is unstable; yet the former reddened litmus paper before the latter. Again:

	Litmus red.	$N_2O_4$ .	Explosion.
Powder No. 265.....	2.05	2.45	3.25
Powder No. 610.....	2.05	2.45	None in 5 hrs.

Here the first and second observations are alike, but No. 610 did not explode and was shown by other tests to be a perfectly stable powder. No. 265 is bad. These examples show that the reddening of blue litmus paper and the appearance of brown fumes in this test, as well as in all other tests where these observations are made, are not always reliable indications of the relative stability of powders. The temperature of  $135^\circ C.$  is usually considered too high for stability testing as it may cause decompositions not always dependent upon the stability. In this test it is sometimes difficult to decide when the litmus paper is red, and when there is the appearance of brown fumes; two operators may vary thirty minutes or even more in the observations of this test. Different makes of litmus paper give different results; the papers used by the Ordnance Department are made according to specifications by Eimer and Amend, and of as nearly uniform quality and sensitiveness as possible.

By keeping all conditions as nearly uniform as possible, this test becomes one of the best of its kind.

#### THE VIEILLE TEST.

Ten grams of the explosive are placed in a strong glass tube or bottle, a piece of blue litmus paper is placed above the sample and

the tube closed air-tight; the tube is then heated in an air-bath at 110° C. until the litmus paper is completely reddened. The time required for this reddening is noted, the bottle removed and opened; this operation is repeated daily until the time required to redden the litmus paper is one hour or less; of course a clean bottle and fresh paper is used each day. The daily times are added and the total (or accumulated) time should not be less than thirty hours for large powders (for 5-inch gun or larger), twenty hours for small powders (less than 5 inches), and ten hours for nitrocellulose. On account of the volatility and danger of explosion of nitroglycerin, powders containing it cannot be tested by this method.

The reddening of the litmus paper indicates only acid products of decomposition and is affected by the moisture-content of the sample. It is practically impossible to have all the Vieille bottles equally tightly closed; experiments have shown that pressure is an important factor in the decomposition of nitrocellulose. The personal equation of the operator affects the readings; varying results are obtained unless the litmus papers used are uniform. The papers used by the Ordnance Department are the same as described under the "135° test."

Results obtained by the Vieille test are reliable only when the explosive is very good or very bad.

#### THE WILL TEST.<sup>1</sup>

Nitrocellulose is decomposed at 135° C. and by means of a current of carbon dioxide, the products of decomposition are carried into a reduction tube containing a heated spiral of copper gauze; this reduces the nitrogen compounds to nitrogen gas which is measured over sodium hydroxide. The nitrogen is measured at regular intervals, and the rate of evolution is taken as an index of the decomposition. A nitrocellulose, which by this test gives equal quantities of nitrogen in equal intervals of time, is considered by Will to be in "the limit state of purification," and therefore as stable as possible. Considering the principle of this test, and in theory it should give better results than any of the other tests so far described.

Will's test was thoroughly tried by Mr. C. P. Beistle of this laboratory, no expense nor time being spared in setting up the

<sup>1</sup> *Mitth. a. d. Centralstelle f. Wissenschaft. Untersuch.*, December, 1900; *Neu Babelsberg*; also abstr. *J. Soc. Chem. Ind.*, June 30, 1900.

rather elaborate and complicated apparatus required, and in conducting the test. The results obtained were unsatisfactory and the test was abandoned.

The following reasons are given as the cause of unsatisfactory results:

(1) The temperature 135° C. is too high for stability testing purposes.

(2) The decomposition is measured only by the nitrogen evolved.

(3) From Professor Will's experiments and diagrams it is not at all clear where to draw the line between a stable and an unstable product.

(4) The statement is made in Professor Will's report that for a certain nitrocellulose, heated for thirty hours and losing one-fourth its original nitrogen, the evolution of nitrogen in equal intervals of time was identical, while in another place it is stated that 10 grams of nitrocellulose gave four times the amount of nitrogen that was given off by 2.5 grams. This latter statement is correct, judging from our own experiments, but it contradicts the former, since the amount of unchanged nitrocellulose in the former experiment is constantly decreasing.

(5) It is practically impossible to buy or make carbon dioxide which is free from air; and as it is difficult to pass carbon dioxide through the apparatus at a uniform rate, the air-content of the gas gives rise to serious errors, and if the current be too fast it may cool the sample, and it will not be completely absorbed by the sodium hydroxide solution; if too slow, the gases of decomposition are not carried away fast enough, which may effect the decomposition, as stated by Professor Will.

(6) If the reduction tube and copper spirals are not heated sufficiently high, or the current of carbon dioxide is passed too fast, some of the products of decomposition may escape reduction.

(7) Unstable products are liable to explode, which might cause considerable annoyance both to the operator and the apparatus.

#### THE NEW TEST.

From a study of the old stability tests, and considering what such tests really ought to show, it must be apparent that none of those in use now are entirely satisfactory. At this laboratory,

NOTE.—For a more detailed description of these tests and illustrations of apparatus, see article by the writer in *Journal of the Franklin Institute*, March, 1903.



explosives are subjected to the potassium-iodide-starch test, explosion, 135° C., and Vieille tests; having made these tests on each sample received, it is unlikely that a really unstable or dangerous explosive has ever been or ever will be accepted. But contradictory results are often obtained (see Table I), due to weak points of these tests.

During a series of experiments for Captain B. W. Dunn, Ordnance Department, U. S. Army, to examine the behavior of powders when subjected to higher temperatures it was noticed that for the same temperature there is a great variation in the behavior of different powders. (Credit is due to Captain Dunn for suggestions and aid in this work.)

If the decomposition of powders increases as the temperature increases, then the behavior of these powders at higher temperatures is an index of their behavior at low temperatures. To prove the relation between temperature and decomposition, a number of powders were heated on watch-glasses in air-baths regulated to different temperatures; at regular intervals the samples were cooled in a desiccator, weighed, and the percentage of loss, due to decomposition and volatilization, calculated. In this series of experiments, powder No. 179, a good nitrocellulose powder, was subjected to temperatures<sup>1</sup> of 80°, 100°, 110°, 115° and 135°; the losses at these temperatures are shown in Fig. 1. After the loss of moisture and solvents, the volatilization of the powder proceeds relatively slowly, but with an increasing rate until a condition is reached which corresponds to the breaking-point of the powder, the action being similar in many respects to that of a metal test specimen in passing its elastic limit. The new test promises to give us, then, *The Elastic Limit of Powder Resistance to Heat*, and this is the new measure proposed for the powder's stability. In Fig. 1, the 110° and 115° curves locate this elastic limit more definitely than the others, the 110° curve at 12, and the 115° curve at 8 days. It is also located at 12 days by the 100° curve, but this temperature is evidently too low. It was not located in thirty days by a temperature of 80°. At 135° no initial stage of resistance could be detected, and it is assumed that at this temperature all powders begin to break down immediately. From the curves on Fig. 1, it is apparent that the best temperature for determining the elastic limit of a normal powder is about

<sup>1</sup> All temperatures are °C.

TABLE I.

Laboratory No. of powder.	Size of grain (inch).	Potassium iodide starch test.			135° C. test.				New 115° C. test.		
		Original. Min.	One year later. Min.	Explosion. Test C.	Litmus rcd.	N <sub>2</sub> O <sub>4</sub> .	Explosion limited to 5 hours.	Vieille test. Hr., min.	Daily loss exceeded 1 per cent.	Maximum daily loss.	Total loss for 6 days. Per cent.
4-11	0.25 × 0.5	15	15	174	1 : 40	None	None	....	From beginning	8	10.22
4-25	0.56 × 0.7	39	30	171	1 : 52	None	None	....	Not reached	Not reached	4.72
155	0.62 × 1.0	16	13	...	2 : 00	None	None	27 : 20	9	13	5.34
179	0.25 × 0.6	35	23	177	4 : 00	None	None	27 : 05	9	Not reached	4.73
197	0.25 × 1.0	..	12	176	1 : 55	None	None	19 : 40	12	14	7.16
210	0.7 × 1.7	28	11	177	2 : 50	None	None	49 : 40	Not reached	Not reached	7.45
262	0.45 × 1.12	18	12	172	3 : 00	None	None	49 : 15	From beginning	8	12.54
265	0.8 × 1.8	15	10	171	2 : 05	2 : 45	3 : 25 3 : 55	29 : 05	From beginning	7	15.89
293	0.8 × 1.8	15	11	166	1 : 20	2 : 20	None	33 : 30	14	Not reached	6.88
294	0.7 × 1.7	10	7	177	2 : 15	None	None	46 : 25	From beginning	6	19.70
326	0.45 × 1.5	30+	30+	161	: 50	2 : 47	3 : 00 4 : 00	24 : 40	From beginning	5	19.39
344	0.7 × 2.0	13	13	150	1 : 15	2 : 22	3 : 00 4 : 15	25 : 10	13	16	6.44
373	0.75 × 1.6	30+	5	175	2 : 35	None	None	36 : 50	11	Not reached	5.11
387	0.4 × 0.9	9	30+	174	3 : 20	None	None	22 : 50	Not reached	Not reached	5.49
389	0.4 × 0.75	10	..	178	1 : 00	None	None	12 : 40	Not reached	Not reached	5.49

TABLE I.—(Continued).

Laboratory No. of powder.	Size of grain (inch).	Potassium iodide starch test.			135° C. test.			Vieille test. Hr., min.	New 115° C. test.		
		Original. Min.	One year later. Min.	Explosion. Test C.	Litmus. red.	N <sub>2</sub> O <sub>4</sub> .	Explosion limited to 5 hours.		Daily loss. exceeded. 1 per cent.	Maximum daily loss.	Total loss for 6 days. Per cent.
391	0.25 × 0.36	12	18	168	: 50	1 : 45	2 : 45 2 : 50	8 : 35	From beginning	5	21.55
396	0.65 × 1.7	20	12	173	3 : 20	None	None	21 : 45	14	Not reached	8.53
405	0.75 × 1.6	30+	17	175	2 : 00	None	None	19 : 15	From beginning	6	18.14
406	0.36 × 1.0	30+	30+	168	1 : 15	3 : 40	3 : 55	15 : 45	From beginning	6	18.80
407	0.6 × 1.3	30+	30+	167	1 : 50	2 : 25	2 : 35	15 : 50	From beginning	7	12.00
445	0.42 × 0.9	15	30+	176	1 : 30	3 : 30	None	31 : 40	11	Not reached	4.83
544	0.25 × 0.63	21	14	176	2 : 15	None	None	30 : 20	Not reached	Not reached	5.11
546 F.A.	0.45 × 1.5	12	30+	170	1 : 20	None	3 : 00 3 : 40	6 : 50	From beginning	3	25.64
577	0.34 × 1.0	12	--	175	1 : 10	1 : 45	None	21 : 45	9	Not reached	6.74
608	0.12 × 1.0	30	--	175	1 : 10	4 : 30	None	16 : 05	6	10	6.05
610	0.8 × 1.8	16	10	178	2 : 05	2 : 45	None	30 : 35	14	Not reached	6.58
619	0.4 × 0.9	6	--	176	2 : 10	3 : 50	None	31 : 15	12	17	5.44
716	0.4 × 0.6	10	--	175	1 : 25	None	None	22 : 00	Not reached	Not reached	4.53
717	0.4 × 0.6	10	--	172	1 : 00	None	None	18 : 55	Not reached	Not reached	5.23

TABLE I.—(Continued).

Laboratory No. of powder.	Size of grain (inch).	Potassium iodide starch test.			135° C. test.			Vieille test. Hr., min.	New 115° C. test.		
		Original. Min.	One year later. Min.	Ex- plosion. Test C.	Litmus red.	N <sub>2</sub> O <sub>4</sub> .	Explosion limited to 5 hours.		Daily loss exceeded 1 per cent.	Maximum daily loss.	Total loss for 6 days. Per cent.
797	0.4 × 0.75	55	--	175	2 : 15	None	None	25 : 40	Not reached	Not reached	5.69
798	0.4 × 0.75	45	--	179	2 : 15	None	None	24 : 50	12	Not reached	4.77
799	0.4 × 0.75	60+	--	177	2 : 30	None	None	22 : 30	10	Not reached	4.32
800	0.62 × 1.0	30+	--	178	2 : 05	None	None	31 : 25	Not reached	Not reached	4.85
803	0.8 × 1.8	27	--	173	1 : 50	3 : 20	3 : 30	24 : 15	From beginning	9	12.37
834	0.4 × 0.87	30+	--	171	3 : 10	None	None	19 : 50	11	Not reached	5.90
836	0.48 × 0.95	30+	--	175	3 : 30	None	None	30 : 45	13	Not reached	7.07
922	0.75 × 1.12	15	--	177	2 : 00	2 : 45	None	31 : 00	Not reached	Not reached	5.00
924	1.0 × 1.75	10	--	175	1 : 40	2 : 45	None	31 : 10	Not reached	Not reached	5.50
926	1.12 × 2.0	10	--	179	2 : 05	3 : 25	None	31 : 00	Not reached	Not reached	5.99

115°. Fig. 2 shows 100°, 110° and 115° curves for a bad powder, No. 391. The elastic limit at 110° is located at nine days, and at 115° at three days. These results (shown in Figs. 1 and 2) prove that there is a definite relation between decomposition and temperature. They show also that a bad powder (No. 391) decomposes much faster, reaching the elastic limit sooner than a good one (No. 179) at the same temperature; after forty-eight hours' heating at 115°, No. 391 lost 21.55 per cent., while No. 179 lost only 5.34 per cent.

The relation between temperature and decomposition, and the fact that a bad powder decomposes faster than a good one having been proved by these results, it remained to be decided which temperature is best suited to distinguish a bad from a good powder. This required a long series of experiments. It is obvious, of course, that the lower the temperature used, the more nearly does the test approach conditions to which a powder is liable to be subjected during storage and handling; but, the higher the temperature used, the shorter will be the time required to show sufficient decomposition to distinguish between a good and bad powder. Although it is very desirable to shorten the time required for making a test, it is not advisable to sacrifice accuracy on this account.

As may be seen from Fig. 1, the decomposition of a powder at 80° is exceedingly slow; even at 100° it is still very slow (Figs.

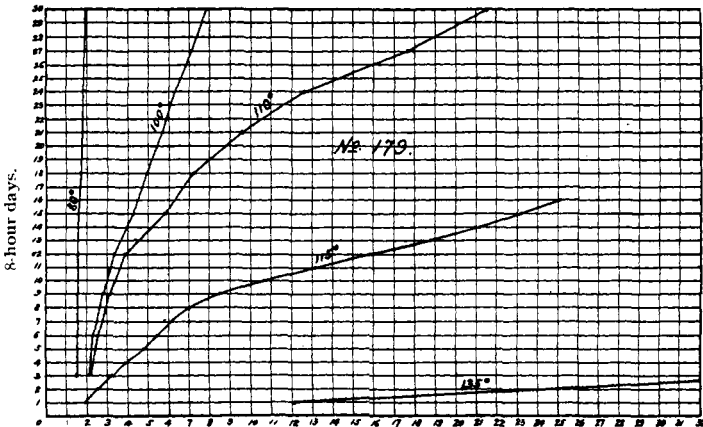

Fig. 1.

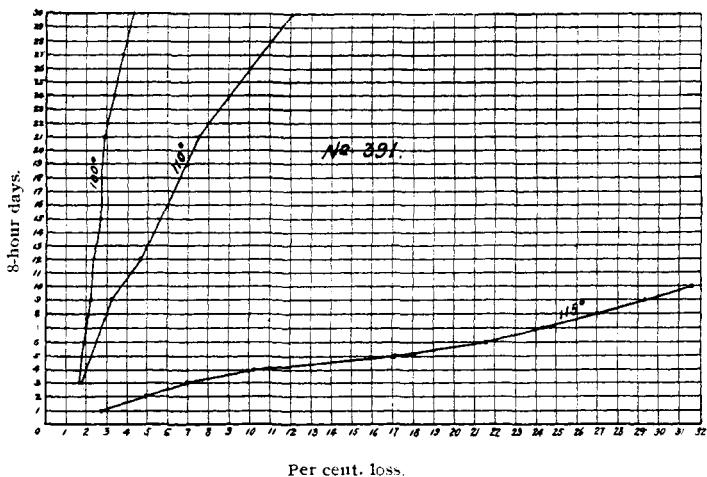

Fig. 2.

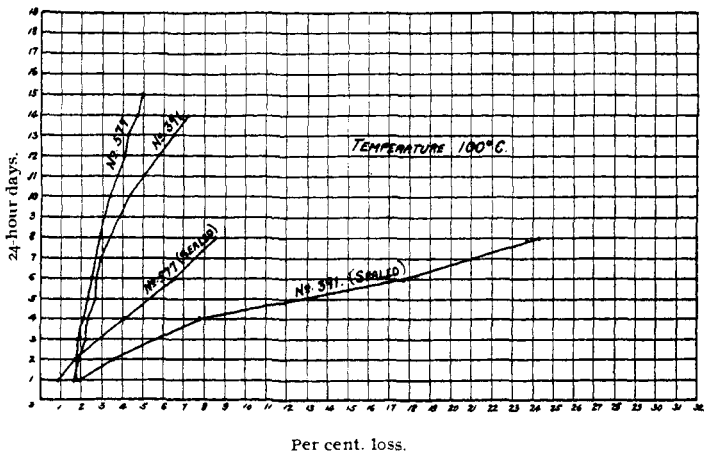

Fig. 3.

1, 2 and 3), but the difference between a good and bad powder becomes quite noticeable at  $100^{\circ}$ , as shown in Fig. 3 by No. 577 (good) and No. 391 (bad). However, the difference is not sufficient, and the time required is too long to be used as a practicable test. Decomposition is greatly increased at  $110^{\circ}$ , and the difference between good and bad powders becomes greater; this is shown in Fig. 4, where Nos. 619, 445 and 577 are very good, and Nos. 391, 326 and 546 F. A. are very bad powders. the others

shown being intermediate. Here again the time required to show the differences is still quite long, too long for practical testing.

The temperature was next increased to  $115^{\circ}$ , and, in order to avoid possible danger from explosions, the exposures were made for eight hours only (during working hours); at the lower temperatures the tests were allowed to run during the night. Three grades of powders were used for all tests—good, bad, and intermediate or doubtful. At  $115^{\circ}$ , decomposition takes place rapidly, and the difference between good and bad powders becomes apparent in a few days as shown in Figs. 5, 6 and 7, which will be more fully discussed later.

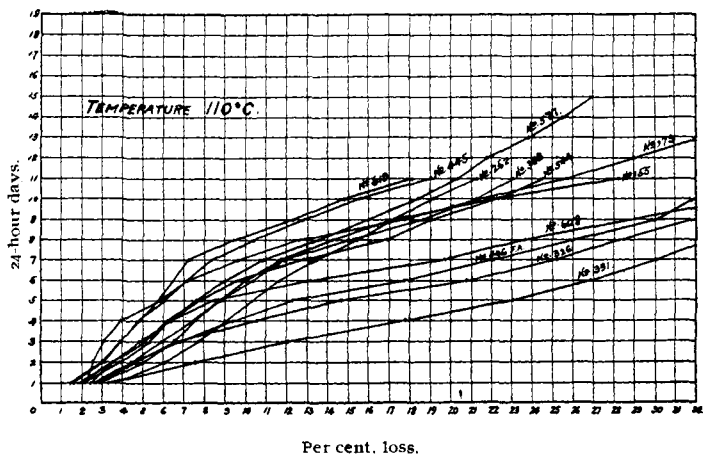

Fig. 4.

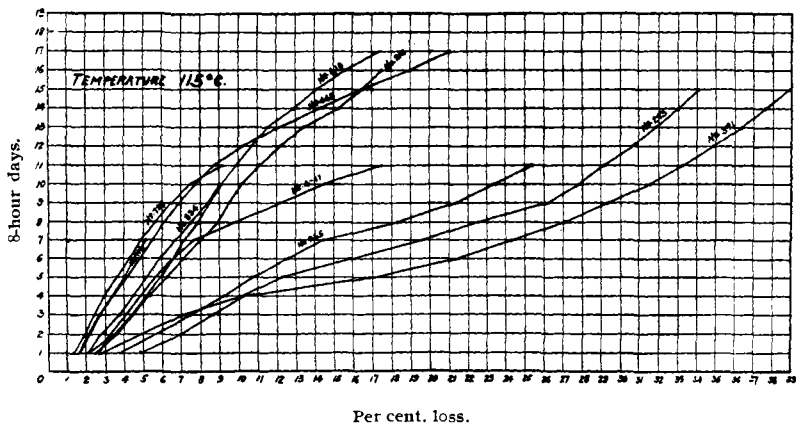

Fig. 5.

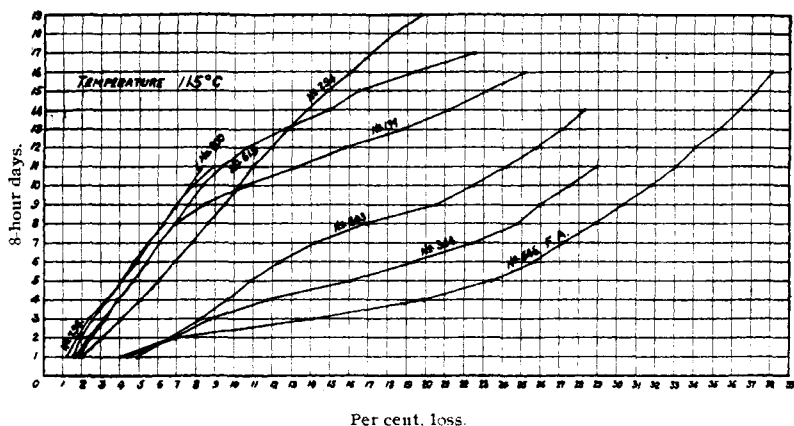

Fig. 6.

Some experiments were made at  $120^{\circ}$ ; the rate of decomposition increased at this temperature, but the difference between a good and bad powder did not seem as great as at  $115^{\circ}$ , all powders decomposing more or less rapidly at  $120^{\circ}$ .

Experiments were made to determine the combined effect of heat and pressure on powders; the weighed samples were placed in small tin boxes and the latter sealed (soldered) air-tight; they were then exposed to  $80^{\circ}$  and  $100^{\circ}$ , the boxes opened and weighed at regular intervals. At  $80^{\circ}$  decomposition is slow, but more rapid than if the powder were heated in the open on a watch-glass, *e. g.*, No. 179 heated at  $80^{\circ}$  lost 9.90 per cent. in forty-one days when sealed, but lost only 2.85 per cent. when heated on a watch-glass at the same temperature and for the same length of time. For a reasonably short time of exposure the difference between a good and a bad powder at  $80^{\circ}$ , sealed, is small. At  $100^{\circ}$ , sealed, the difference between a good and bad powder becomes quite marked, as may be seen from Fig. 3; this figure also shows that the difference between a good (No. 577) and a bad powder (No. 391) is greater when sealed and decomposed under pressure than when heated in the open; the time required is also reasonably short. It will be observed that the effect of pressure is the same as that of an increase in temperature. It is probable that more extensive experience may result in the adoption of a "sealed" method of testing. A form of holder must be devised, however, better than the bottles used in the Vieille test. The sealing features of this holder must be reliable and convenient. It will



probably be of metal with a convenient method of sealing by pressure derived from a screw thread, and not depending upon a rubber gasket. In addition to shortening the time required for tests at a given temperature, the sealing method is preferred because it corresponds more nearly to the conditions of storage of powders. In fixed ammunition the powder charges are almost if not quite hermetically sealed to make the ammunition water-proof, and when stored in large metal-lined boxes in magazines the quantity of powder is very large as compared with test specimens, and the space for the volatile matter to collect very small. It is intended to hermetically seal the storage cases by soldering.

From these preliminary experiments it appeared that when heating the powders unconfined,  $115^{\circ}$  gave the best results. Considering the importance of a knowledge of the stability of a powder, the time required to get results at  $115^{\circ}$  may be considered reasonably short.

For some of the preliminary tests an ordinary sheet-copper

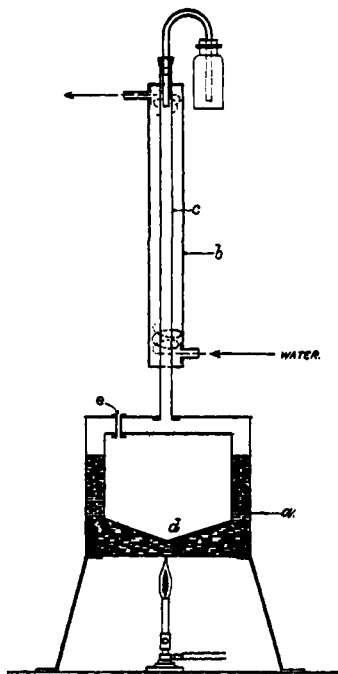

Fig. 7.

air-bath or oven was used; the temperature was regulated

by means of a gas regulator or thermostat; however, it was a matter of considerable difficulty to keep the oven at  $115^{\circ}$ , and under the most favorable conditions it was impossible to avoid variations of  $+1^{\circ}$  or  $2^{\circ}$ . In order to obtain a more uniform temperature, an oven shown in Fig. 1 (diagrammatic sketch) was devised. The oven part is double-walled, of heavy sheet-copper, similar to the ordinary double-walled water-ovens; but in order to prevent bumping and jarring, which is a common fault of all water-ovens, the bottom part of the inner wall was made slightly V-shaped; this arrangement causes the contents of the oven to boil quietly, and effectively prevents bumping. A reflux condenser in the top of the oven prevents the volatilization of the boiling mixture. The latter consists of commercial xylene and toluene in such proportion that when the mixture is boiling, the temperature of the air on the inside of the oven is  $115^{\circ}$ . This arrangement is simple and has been found perfectly satisfactory, the temperature varying less than  $0.5^{\circ} +$  or  $-$ . The opening *E* is for a thermometer; the oven has two shelves, and an opening (closed by a screw plug) for introducing the xylene-toluene mixture; these are not shown in the sketch.

The test adopted, pending further developments, is as follows: From one to four whole pieces of the powder to be tested are weighed on a watch-glass and heated for eight hours in the  $115^{\circ}$  oven; the sample is allowed to cool in a desiccator and weighed; the loss in weight is calculated to percentage. This is repeated from day to day until completion of test (6 days, or less).

A large number of powders have been subjected to this method of testing, and some of the results are shown in Figs. 5, 6 and 7. In Fig. 5 the powders numbered 391, 293 and 265 are bad, 4-11 are doubtful, while the others are good. In Fig. 6, Nos. 546 F. A., 344 and 803 are bad, the others are good. In Fig. 7, Nos. 326, 406 and 405 are bad, 4-25 are doubtful, while the others are good. The powders indicated as bad had previously been diagnosed as such by a careful study of the combined results of four of the old stability tests (see Table I).

In the new test at  $115^{\circ}$  during the first day's heating, a good powder loses approximately its moisture and volatile matters; after this, the daily loss is less than 1 per cent., but gradually increases until a maximum is reached, after which it slowly decreases. The daily loss of a good powder does not exceed 1 per

cent. before the sixth day, often not before the tenth day. The maximum daily loss is usually not reached before the eighth day. A bad powder usually loses more than its moisture and volatile matters on the first day; the daily loss is more than 1 per cent. before the sixth day and the maximum daily loss occurs before the eighth day.

*The total loss of a good powder for six days is less than 10 per cent.; bad powders lose considerably more than 10 per cent. in six days.* By this test, therefore, it is possible to obtain reliable indications as to the stability of a powder in six days of eight hours each. In special cases where it is necessary to get results more quickly, the exposures could be made for twenty-four hours, or weighings could be made at eight-hour intervals, and results obtained in a little over two days.

After prolonged heating, good and bad powders approach the same total loss (Fig. 8). Preliminary analyses of the residues

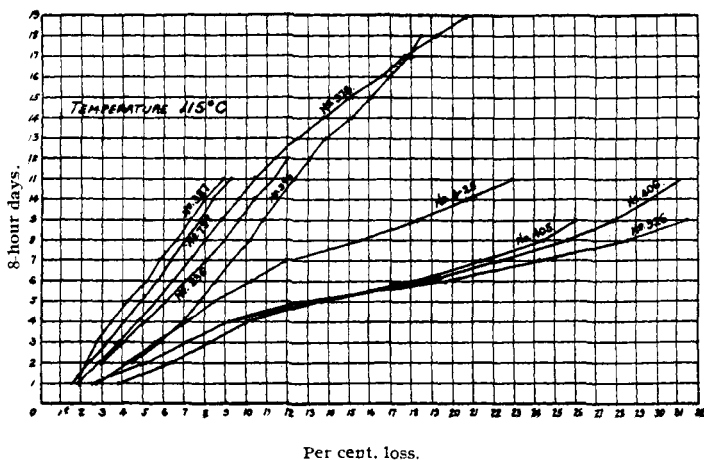

Fig. 8.

from these heat tests indicate that the decomposition of the powders by heat is a complex reaction or process. Most powders become quite brittle and porous but still retain their shape, the decomposition being a sort of destructive distillation; a few powders, usually bad, lost their shape, being fused and soft while hot, porous and brittle when cold. The percentage of nitrogen decreases as the total loss increases. With a total loss of 55 to 56 per cent. the nitrogen in the residue was found to be 4.31 to

4.91 per cent. (15 samples examined; original nitrogen 12.37 to 12.60 per cent.). This agrees with the fact that the loss curves

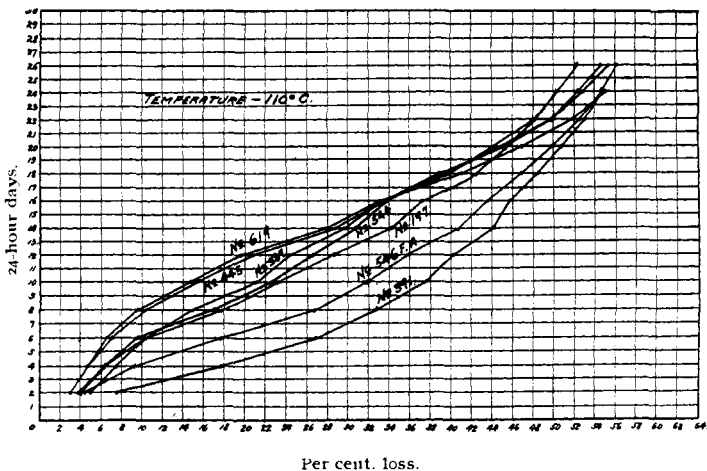

Fig. 9.

(Fig. 8) are close together at 55 to 56 per cent. "Acetone insoluble" nitrocellulose increases with total loss:

Total loss. Per cent.	"Acetone insoluble" nitrocellulose. Per cent.
41.37	0.12
55.67	0.72
65.08	6.99

Analysis of residues as well as volatile products of decomposition

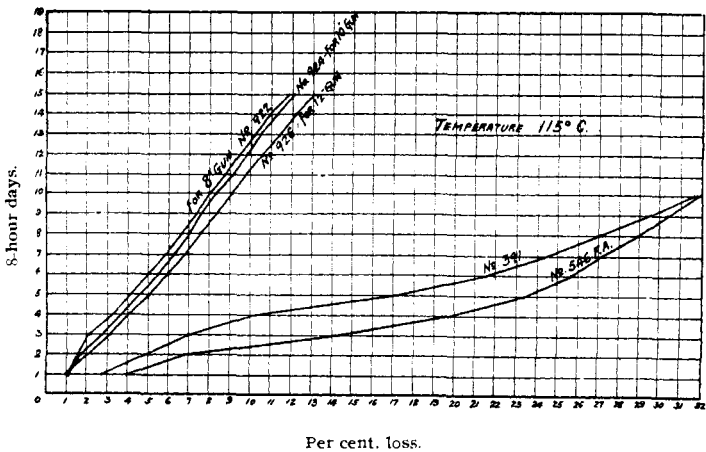

Fig. 10.

is to be the subject of future investigation. The size of the grain of powder affects the decomposition slightly, but not sufficiently to be taken into consideration when distinguishing a bad from a good powder by this test; decomposition of a powder increases slowly as the size of the grain increases; this is shown in Fig. 9. Powders Nos 922, 924 and 926 are made from the same lot of nitrocellulose, as nearly alike as possible, except in size as indicated in Fig. 9. Powders Nos. 391 and 546 F. A. are bad powders, shown for comparison.

Results of four old stability tests, and of the new test, are shown in Table I. A study of this table shows that the old tests often give contradictory results, due to weak points of these tests as pointed out in their description. The requirements for a good or stable powder by the old tests are, for

- Potassium-iodide-starch test, 10 minutes.
- Explosion test, 177° C.
- 135° test { Litmus red, 1.15.  
N<sub>2</sub>O<sub>4</sub> fumes, 2.00.  
Explosion, none in five hours.
- Vieille test { Twenty hours for five-inch powders.  
Thirty hours for powders larger than five-inch gun.

Table II, made from Table I and the above requirements, shows how results from the old tests often contradict each other as well as that obtained from the new test: the new test is always corroborated by one or more of the old tests.

TABLE II.

No.	New 115° test.	Potassium-iodide-starch test.	Explosion test.	130° test.	Vieille test.
293	Bad	Good	Bad	Good	Good
294	Good	Bad	Good	Good	Good
326	Bad	Good	Bad	Bad	Bad
344	Bad	Good	Bad	Bad	Bad
396	Good	Good	Bad	Good	Bad
405	Bad	Good	Bad	Good	Bad
619	Good	Bad	Bad	Good	Good
717	Good	Good	Bad	Good	Bad
834	Good	Good	Bad	Good	Bad

The new test has the following advantages over the old method:

- (1) The powder is tested in its natural condition.
- (2) It shows all products of decomposition; the old tests show only acid products, or, the Will test, only nitrogen.

(3) It shows the decomposition of nitro-compounds other than nitrocellulose which are often present in a finished powder, and it also shows the effect of this decomposition on the powder itself.

(4) It shows the effect on the stability of a powder, of small quantities of added substances (for masking stability or other purposes); volatile matter; handling and working which may set up local decomposition; traces of nitrating acids due to imperfect purification; decomposition due to saponification<sup>1</sup> by water, alkalies, carbonates, etc.

(5) It shows quantitatively the progress of all decomposition.

(6) The test itself, as well as the apparatus, is simple and not subject to variations like the old tests.

CHEMICAL LABORATORY, FRANKFORD ARSENAL,  
PHILADELPHIA.

---

## A STUDY OF THE DOUBLE CYANIDES OF ZINC WITH POTASSIUM AND WITH SODIUM.

BY W. J. SHARWOOD.

Received March 30, 1903.

DURING the precipitation of gold and silver by means of metallic zinc, from the solutions obtained in the cyanide process of extracting precious metals from their ores, more or less zinc is dissolved and accumulates to a certain extent in these solutions, and its presence in some instances modifies or complicates the estimation of the simple alkaline cyanide in such solutions, and also slightly affects their subsequent action on some of the constituents of the ores or other materials treated by them.

A typical solution might have originally contained one-fourth of 1 per cent. of potassium cyanide, to which about the same amount of calcium hydroxide or sodium hydroxide might be added, after which, with occasional additions of the same reagents, it has been filtered alternately through pulverized ore and finely divided metallic zinc, several tenths of a per cent. of which might be found in the final solution. Some discussion has arisen as to the forms in which the zinc and cyanogen may be distributed in such a solution, whether, for instance, the zinc is in the form of a zincate ( $K_2ZnO_2$ ) or a double cyanide ( $K_2ZnCy_4$ ). The latter opinion has been more generally favored, but after a cyanide solution has been in use for some months—judging from the published analyses

<sup>1</sup> Thomas: *Ztschr. angew. Chem.*, (1899), p. 55.